

SHERWOOD®

The Original Engine Cooling Pump Since 1921

www.sherwoodpumps.com

R Series Technical Guide

Identification



E35



R30G-1



R10870G



R30G



R50G



R102

Assembly / Disassembly Instructions

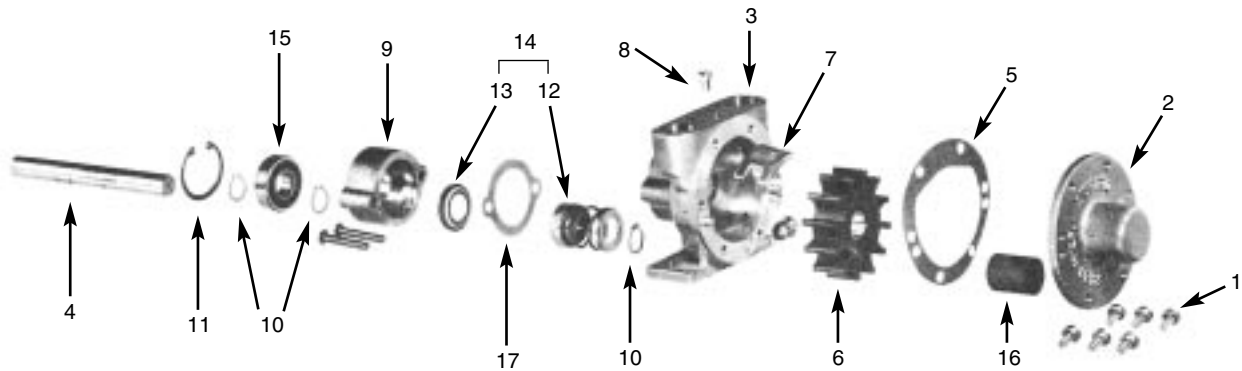

The following assembly/disassembly procedures apply to all R Series pumps. Deviations from pump to pump are primarily a result of different methods of drive and mounting. Pump numbers can be found on the tag or stamped on the pedestal base of the pump.

Disassembly:

- A. Remove the screws (1) and lockwashers that hold the cover to the body (3). Pull the cover and bushing assembly (2) off the drive shaft (4).
- B. Remove the vellum gasket (5). Sherwood recommends replacing the gasket each time the pump is assembled, however, if you plan to use the same gasket, it should be submerged in water until pump is reassembled. If gasket dries, it will shrink.
- C. The impeller (6) can now be removed by using pliers and grasping a vane on one side, then the other, alternating positions and gently pulling. Make sure you have a good grip on each vane so the pliers will not slip and damage the impeller.
- D. The cam (7) can be removed by removing the screw (8) that goes down through the top of the body between the intake and discharge ports.
- E. Remove the two screws (18) and lockwashers from the bearing housing (9) on the drive shaft end of the housing. This will allow you to remove the bearing housing, seal assembly, and shaft from the body.
- F. Remove the woodruff key from the shaft. If the shaft is to be used again and if it is put in a vise, always use lead over the jaws of the vise so that the shaft is not damaged.
- G. Remove the retaining ring (10) from the shaft at the seal end. The seal (12) can now be removed from the shaft. Note how the seal and seat assembly (14) are arranged so they can be properly reassembled.
- H. By removing the large internal retaining ring (11) from the bearing housing, the bearing (15) and shaft can be pressed out of the bearing housing. Support the bearing housing, and press on the shaft from the impeller end.
- I. Pumps designed without separate bearing housings may require shaft removal from opposite end depending on housing design.
- J. The seat assembly (13) is pressed into the bearing housing and can be removed by pushing a tool through the bearing end and against the rubber or backside of the seat.

Assembly:

- A. When replacing the carbon bushing (16) in the cover, care should be taken not to crack the bushing. A tool that pilots on the inside diameter and presses uniformly against the end of the bushing is recommended.
- B. When assembling the cam (7), put Permatex #1 on back side of cam and the screw (8) that retains the cam. Wipe off any Permatex that gets into the impeller cavity.
- C. Assemble a retaining ring (10) on the shaft into the second groove from the drive shaft end. Push the ball bearing (15) over the shaft (4). Press on the inner race of the bearing. Push the bearing up against the retaining ring. Assemble the second snap ring (10) over the shaft and up against the ball bearing, from the flat shaft end.
- D. Push the bearing and shaft assembly into the bearing housing (9) using care not to cock the bearing. A tool is recommended that will give you uniform pressure on the bearing outer race. Lock the bearing in place with the large internal retaining ring.
- E. From the opposite end (woodruff key end of the shaft), assemble the seat (13) over the shaft, rubber side first. Push it into the counter bore in the bearing housing. Do not damage (scratch) the white ceramic surface on the seat, or the seal and seat assembly might leak.
- F. Push the seal assembly (12) over the shaft and down against the seat. Do not damage the black carbon washer that rides against the ceramic.
- G. Assemble the third retaining ring (10) on the shaft. It will be necessary to compress the seal assembly to allow the retaining ring to enter the groove on the shaft.

Assembly / Disassembly Instructions (continued)

- H. Press the woodruff key into the keyway in the shaft.
- I. Assemble the small gasket (17) over the pilot on the bearing housing and assemble the complete shaft, bearing, seal assembly, to the body. Use the two long screws for fastening the bearing housing to the body.
- J. Assemble the impeller (6) over the shaft (4). Line up the key in the shaft with the keyway in the impeller, and push the impeller into the body (3).
- K. Push the gasket (5) and cover (2) over the dowel pins, and attach the cover with the screws (1) and lockwashers.

Sherwood #		R30G	R30G-1	R10870G	R50G	R102	E35	
Port Size (NPT)		1/2"	1/2"	3/4"	3/4"	1"	1"	
Shaft Drive Description		Flat	Keyed	Keyed	Flat	Keyed	Pulley Hub	
ITEM	QTY							
1	Screw	4/6	12686	18999	01482	01482	01483	01483
2	Cover Assy	1	10281	10281	10096	10096	10183	10183
3	Body Assy	1	10597	10597	10177	10177	18503	11246
4	Shaft	1	10289	11854	10852	10175	18502	11744
5	Gasket, Cover	1	10286	10286	10103	10103	10931	10931
6	Impeller	1	10077	10077	09959	09959	10615	10615
7	Cam	1	10285	10285	10072	10072	10929	10929
8	Cam Screw	1	10195	10195	09919	09919	10515	10515
9	Bearing/Housing Assy	1	10198	10198	10172	10172		
10	Retaining Ring (Ext)	3	04304	04304	04258	04258	04258	04258
11	Retaining Ring (Int)	1	04303	04303	04259	04259	04259	04259
12	Seal	1	10522	10522	18743	18743	18743	18743
13	Seat	1	11361	11361	10926	10926	10926	10926
14	Seal/Seat Assy	1	11367	11367	10927	10927	10927	10927
15	Ball Bearing	1	04306	04306	04257	04257	04257	04257
16	Bushing	1	02075	02075	06333	06333	06333	06333
17	Gasket, Housing	1	10197	10197	10171	10171		
18	Screws	2	05437	05437	04265	04265		
	Key	1	10093	10093	04432	04432	04432	04432
	Dowel Pin	2	01311	01311	01311	01311	01311	01311
	Plug	1/2	00336	00336	00336	00336	00336	00336
	Hub	1						97176
	Minor Repair Kit		10996	10996	10997	10997	10999	10999
	Major Repair Kit		24025	24025	12937	12937	11068	11068

Inspection

The #1 reason for premature engine wear is overheating. To maintain engine performance, insist upon genuine Sherwood impellers and service kits.

Recommended inspection to be performed at any service interval:

- Impeller Inspect for cracks or tears. Also inspect for excessive abrasion of vane ends. Replace annually, or if any of the conditions exist as in the picture below.*
- Cam Replace at major pump rebuild or if pitting/wear is evident.
- Cover Replace if wear exists, to maintain pump flow and suction performance.
- Mechanical Seal Replace at minor and major pump rebuild or if leaking.
- Shaft Inspect for wear in area of the rubber impeller. Heavy fretting of the impeller end shaft will require shaft replacement.
- Bearing Inspect for loss of grease, corrosion or rough rotation. Replace at major pump rebuild or if in doubt.

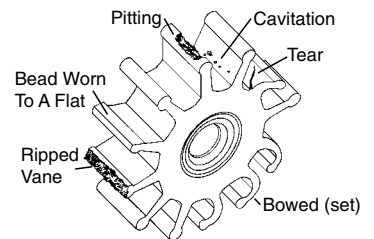

* See maintenance schedule on page 3

Preventative Maintenance

Maintenance Schedule	Pleasure Boating (Low Hours)		Commercial/Fishing Use (High Hours)	
	Light Duty	Severe Duty (High RPM, Silt or Sand)	Heavy Duty	Severe Duty (High RPM, Silt or Sand)
Impeller Kit	Every year	6 months	6 months	3 months
Minor Kit	2 years	Every year	Every year	6 months
Major Kit	4 years	2 years	2 years	Every year

The #1 reason for premature engine wear is overheating. To maintain engine performance, insist upon genuine Sherwood impellers and service kits.

	Impeller Kit	Minor Kit 10996	Minor Kit 10997	Minor Kit 10999	Major Kit 24025	Major Kit 12937	Major Kit 11068
	1-Impeller 1-Gasket	1-10077 Impeller 1-10197 Gasket 1-10286 Gasket 1-11367 Seal Assy 1-04304 Snap Ring 1-10093 Key	1-09959 Impeller 1-10103 Gasket 1-10171 Gasket 1-10927 Seal Assy 1-04258 Snap Ring 1-04432 Key	1-10615 Impeller 1-10931 Gasket 1-10927 Seal Assy 1-04258 Snap Ring 1-04432 Key	1-10077 Impeller 1-10197 Gasket 1-10197 Gasket 1-11367 Seal Assy 3-04304 Snap Ring 1-02075 Bushing 1-04306 Bearing 1-10285 Cam 1-04304 Snap Ring 1-10093 Key	1-09959 Impeller 1-10103 Gasket 1-10171 Gasket 1-10927 Seal Assy 3-04258 Snap Ring 1-06333 Bushing 1-04257 Bearing 1-10072 Cam 1-04259 Snap Ring 1-04432 Key	1-10615 Impeller 1-10931 Gasket 1-10927 Seal Assy 2-04258 Snap Ring 1-04257 Bearing 1-04259 Snap Ring 1-04432 Key 1-06333 Bushing 1-10929 Cam
R30G	10077K	X			X		
R30G-1	10077K	X			X		
R10870G	09959K		X			X	
R50G	09959K		X			X	
R102	10615K			X			X

SHERWOOD®

HYPRO®
 A WICOR COMPANY

MARINE PRODUCTS GROUP

375 Fifth Avenue NW • New Brighton, MN 55112-3288

Phone: (651) 766-6300 • 800-471-0460 • Fax: 800-672-7023

www.hypropumps.com www.sherwoodpumps.com